

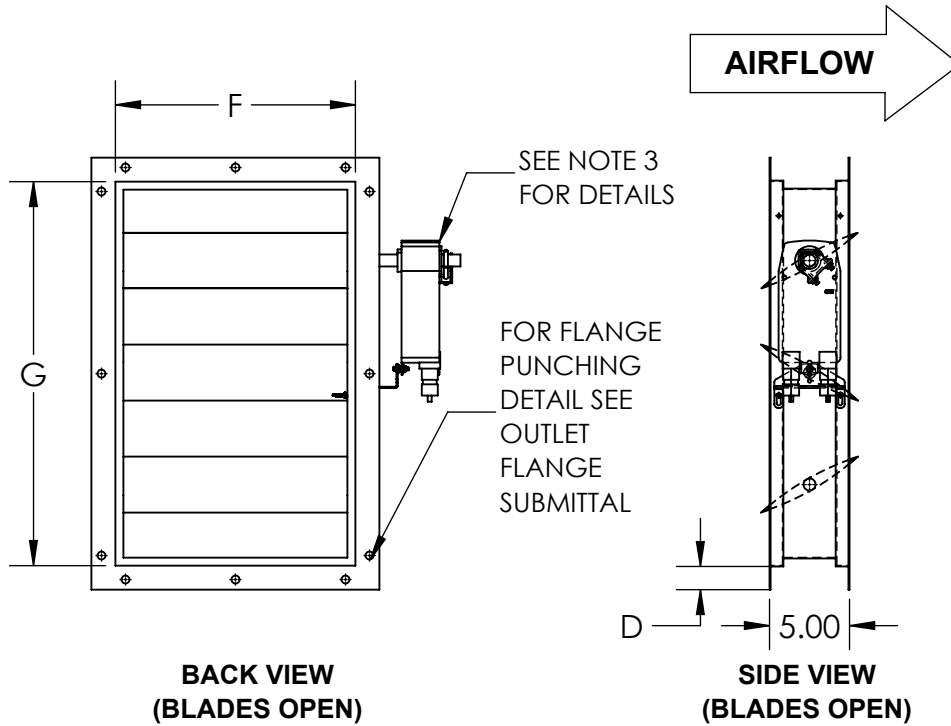

DATE: TAG:
 JOB:
 PROJECT:
 COMPANY:
 SALES PERSON:

UTILITY VENT SET FAN
 UVS2, CLASS 1 AND 2, CONTROL DAMPER



NOTES :

1. Control Damper to be double flanged, punched, and opposed airfoil bladed.
2. Galvanized and extruded Aluminum construction.
3. NEMA 2, Spring Return Actuator, Fail Open, 2 SPDT Auxiliary Limit Switch, available in 24V, 115V, or 230V.
4. Shipped loose.

| MODEL SIZES | D | F | | | | | | | | | | | G | |
|-------------|------|-------|-------|-------|-------|-------|-------|-------|-------|-------|-------|-------|---|-------|
| | | 100% | 95% | 90% | 85% | 80% | 75% | 70% | 65% | 60% | 55% | 50% | | |
| 060 | 1.5 | 8.19 | - | - | - | - | - | - | - | - | - | - | - | 11.56 |
| 070 | 1.5 | 8.19 | - | - | - | - | - | - | - | - | - | - | - | 11.56 |
| 080 | 1.5 | 8.19 | - | - | - | - | - | - | - | - | - | - | - | 11.56 |
| 105 | 1.5 | 8.19 | - | - | - | - | - | - | - | - | - | - | - | 11.56 |
| 122 | 1.5 | 9.88 | 9.75 | 9.56 | 9.44 | 9.25 | 9.06 | - | - | - | - | - | - | 13.06 |
| 135 | 1.5 | 10.88 | 10.75 | 10.56 | 10.38 | 10.19 | 10.00 | 9.81 | - | - | - | - | - | 14.38 |
| 150 | 1.5 | 12.06 | 11.88 | 11.69 | 11.50 | 11.31 | 11.06 | 10.88 | 10.69 | 10.50 | - | - | - | 15.88 |
| 165 | 1.5 | 13.25 | 13.06 | 12.81 | 12.63 | 12.44 | 12.19 | 11.94 | 11.75 | 11.50 | 11.31 | - | - | 17.56 |
| 182 | 1.5 | 14.06 | 13.88 | 13.63 | 13.38 | 13.06 | 12.88 | 12.63 | 12.38 | 12.13 | 11.88 | 11.63 | - | 20.06 |
| 200 | 1.75 | 15.38 | 15.13 | 14.88 | 14.63 | 14.38 | 14.13 | 13.88 | 13.50 | 13.25 | 13.00 | 12.75 | - | 22.00 |
| 222 | 1.75 | 17.13 | 16.88 | 16.63 | 16.25 | 16.00 | 15.75 | 15.38 | 15.13 | 14.75 | 14.50 | 14.13 | - | 24.50 |
| 245 | 1.75 | 18.75 | 18.50 | 18.13 | 17.88 | 17.50 | 17.13 | 16.88 | 16.50 | 16.13 | 15.88 | 15.63 | - | 27.00 |
| 270 | 1.75 | 20.63 | 20.38 | 20.00 | 19.63 | 19.38 | 18.88 | 18.50 | 18.13 | 17.75 | 17.38 | 17.13 | - | 29.75 |
| 300 | 1.75 | 23.00 | 22.63 | 22.25 | 21.88 | 21.50 | 21.00 | 20.63 | 20.25 | 19.88 | 19.38 | 19.13 | - | 32.88 |
| 330 | 1.75 | 25.25 | 24.88 | 24.38 | 24.00 | 23.63 | 23.13 | 22.63 | 22.25 | 21.75 | 21.38 | 21.00 | - | 36.19 |
| 365 | 1.75 | 27.88 | - | - | - | 26.13 | - | - | - | - | - | 23.25 | - | 40.06 |
| 402 | 2.00 | 30.75 | - | - | - | 28.88 | - | - | - | - | - | 25.63 | - | 44.13 |
| 445 | 2.00 | 34.00 | - | - | - | 31.88 | - | - | - | - | - | 28.25 | - | 48.75 |
| 490 | 2.00 | 37.50 | - | - | - | 35.13 | - | - | - | - | - | 31.13 | - | 53.50 |
| 542 | 2.00 | 41.50 | - | - | - | 38.88 | - | - | - | - | - | 34.50 | - | 59.19 |

ALL DIMENSIONS ARE IN INCHES

REVISION:

FORM:

REPLACES: